

FreshGround (XL) / FreshMore

OPERATING MANUAL



700.470.016C (Digital manual - English)

- Model-no:**
- FRSHN4-501
 - FRSHN4-502
 - FRSHN4-510
 - FRSHN4-511
 - FRSHN6-101

All rights reserved.

No part of this document may be copied and/or published by means of printing, photocopying, microfilming or by any other means whatsoever without the prior written consent of the manufacturer. This also applies to the included drawings and/or diagrams.

The information in this document is based on data that was available at the time the design, the material characteristics and the operating methods were published, meaning that this document is subject to change.

The original instructions for this manual have been written in English. Other language versions of this manual are a translation of the original instructions.

For this reason, the instructions are merely a guideline for the installation, maintenance and repair of the machine shown on the front cover.

This document applies to the standard version of this machine.

The manufacturer therefore declines all liability for any damage arising from specifications that deviate from the standard version of the machine delivered to you.

This document has been compiled with the utmost care. However, the manufacturer cannot be held liable for any errors it contains or the consequences thereof.

Table of contents

1. General	<u>1</u>
2. Parts and functions	<u>1</u>
2.1 Parts FreshGround	<u>1</u>
2.3 Parts FreshMore	<u>2</u>
2.2 Optional water filter	<u>2</u>
3. Cleaning	<u>3</u>
3.1 Frequent cleaning (weekly)	<u>3</u>
3.2 Periodic cleaning (monthly)	<u>6</u>
4. Recipes (ex-factory)	<u>8</u>
4.1 Beverages per configuration	<u>8</u>
4.2 Recipes	<u>9</u>

1. General

- ▶ Always read the safety instructions (700.403.347).
To avoid possible damage, these safety instructions must be read, understood and followed.
- ▶ Manuals are subject to change, scan the QR code to retrieve current information.



2. Parts and functions

2.1 Parts FreshGround

1. canisters for instant ingredients
2. canister outlet
3. mixing system
4. beverage outlet
5. hot water outlet
6. bean canister
7. grinder outlet
8. brewer
9. filter belt
10. filter roll holder
11. special keys
 - 11a. service key (door)
 - 11b. override key (lid / bean canister)
12. USB port
13. program button
14. door key
15. waste bin
16. drip tray with float
17. ventilation system
18. water inlet
19. electrical connection
20. on/off switch

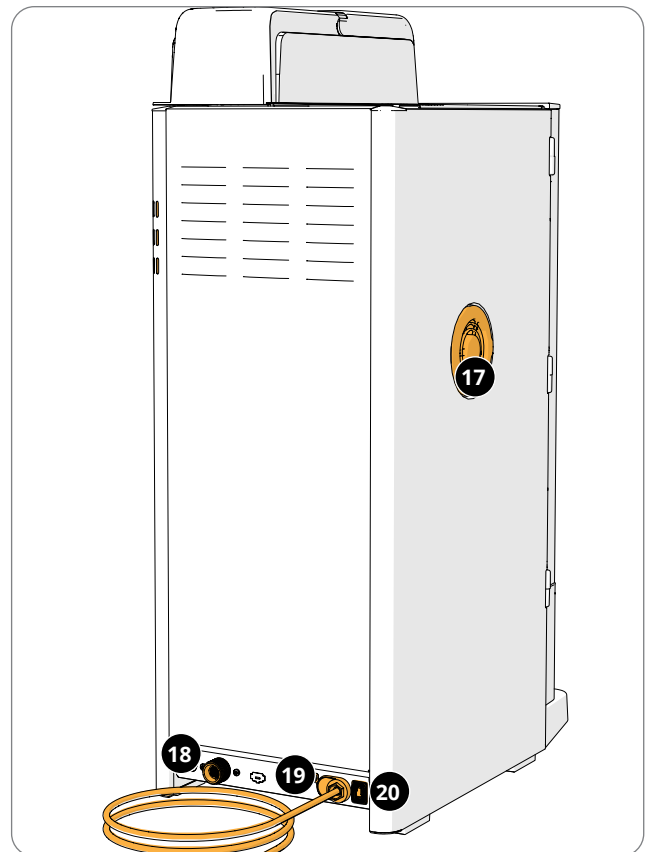
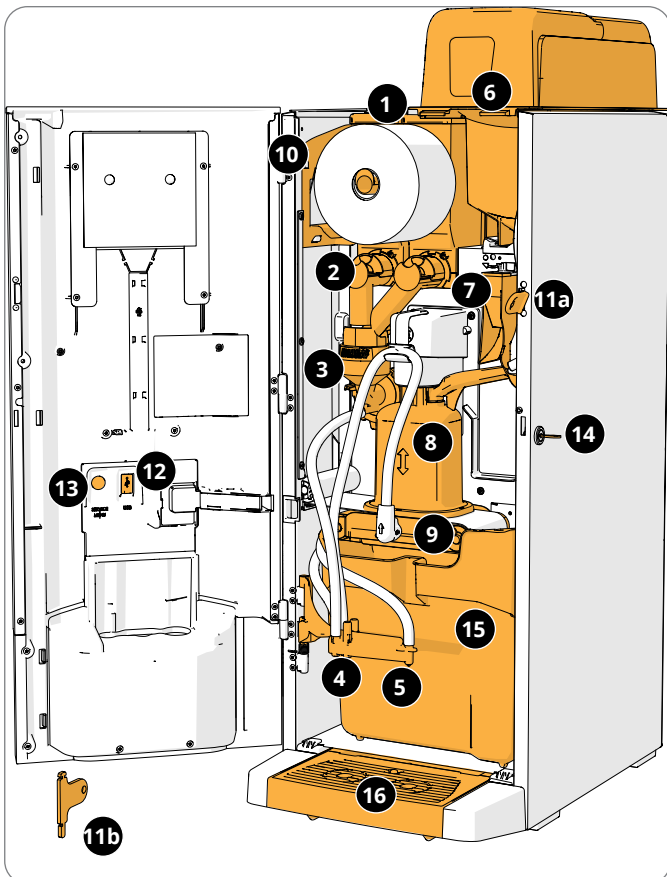

2.3 Parts FreshMore

- | | |
|--------------------------------------|---------------------------|
| 1. canisters for instant ingredients | 11. special keys |
| 2. canister outlet | 11a. service key (door) |
| 3. mixing system | 11b. override key (lid) |
| 4. beverage outlet | 12. USB port |
| 5. hot water outlet | 13. program button |
| 6. freshbrew coffee canister | 14. door key |
| 7. outlet for instant coffee | 15. waste bin |
| 8. brewer | 16. drip tray with float |
| 9. filter belt | 17. ventilation system |
| 10. filter roll holder | 18. water inlet |
| | 19. electrical connection |
| | 20. on/off switch |

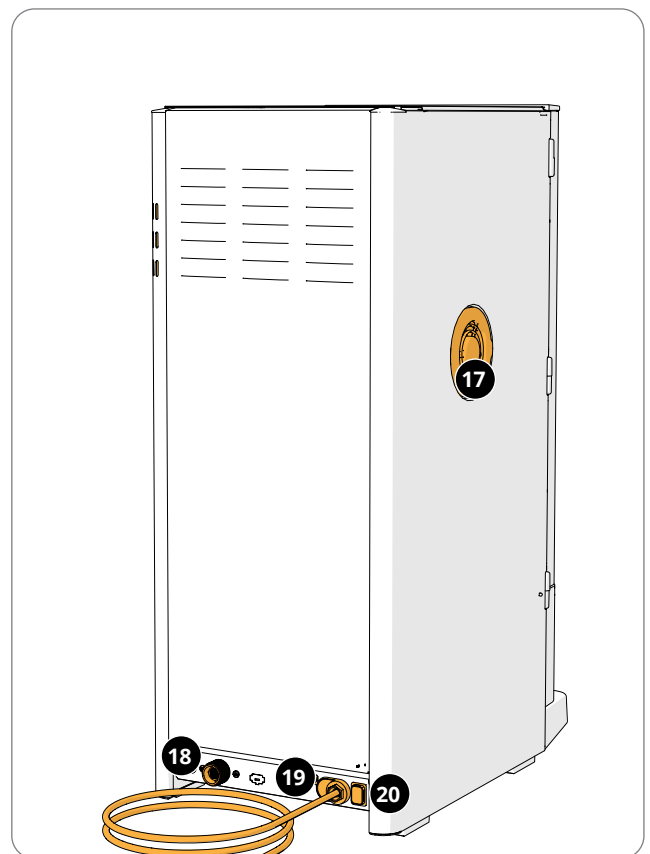
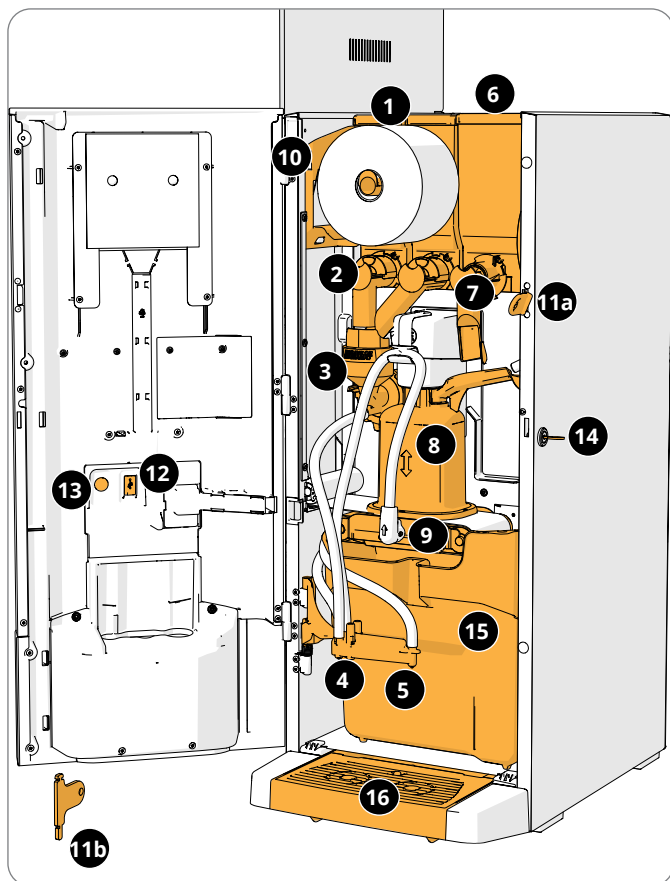

2.2 Optional water filter

To enjoy your beverages even more and improve the performance of your FreshBrew, we recommend installing a water softener filter. You can request one from Bravilor Bonamat BV.

- *When you install a water softener, you must specify this in the FreshBrew GUI. Go to 'Settings' – 'Water filter'.*

3. Cleaning

It is important that the FreshBrew is kept clean, what can be cleaned (*period depends on pollution*):

Daily	Frequently	Periodically
Run the rinse program Empty drip tray	Drip-tray Mixing system Outside Waste bin Rinse Brewer (after 1200 cups or weekly, see GUI)	Cleaning Brewer (after 5000 cups or monthly, see GUI) Ventilation system Instant canister and inside

- ▶ *Never clean parts of the FreshBrew in the dishwasher, only if this is explicitly stated.*
- ▶ *Do not use any aggressive cleaning agents.*
- ▶ *See also the cleaning programmes in the GUI.*

3.1 Frequent cleaning (weekly)

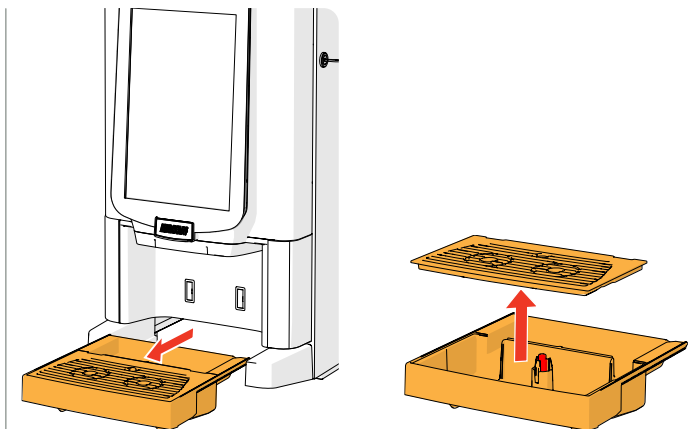

Drip-tray

1. pull the complete drip tray forward
 2. empty the drip tray
 3. clean the drip tray (including grid), using *hot soapy water*
 4. dry everything and place them back in place
- ▶ *Check whether the "red float" is still in place.*

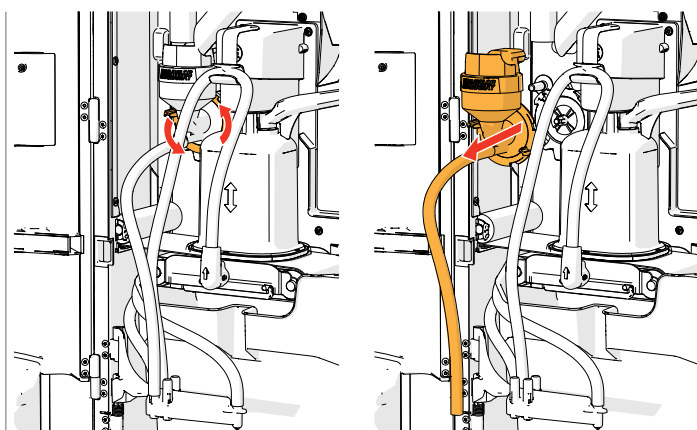

Mixing system

1. open the door and lid
2. turn the fixation ring counter-clockwise
3. remove the complete mixing system

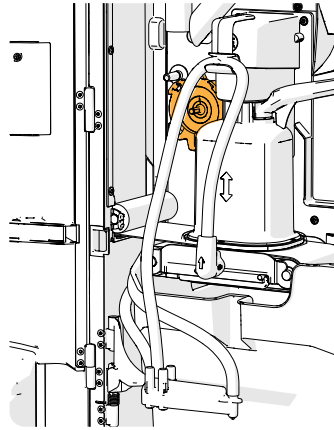
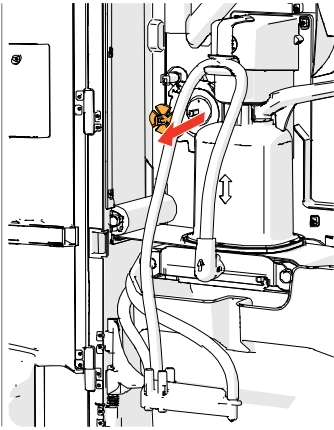

4. remove the mixer
5. clean the indicated parts, using a *damp* cloth

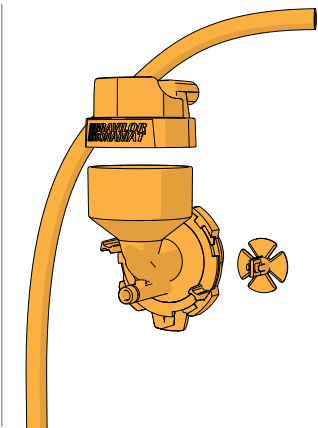

6. clean the removed parts (*dishwasher proof* (<math><65^{\circ}\text{C}</math>))
 7. remount the mixing system in reverse order
- *Pay attention to the flat sides of the shaft and the mixer.*
8. reconnect the hose to the mixing system and the outlet
 9. close the lid and door

► *To prevent clogging of ingredient that has fallen into the mixing cup, it is recommended to rinse the machine after the daily cleaning procedure.*

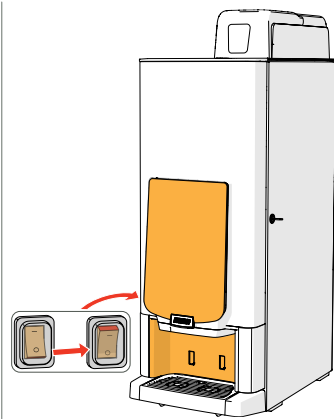

The outside

1. switch off the machine (due to the touchscreen)
2. clean the outside with a *damp* cloth
3. switch the machine back on

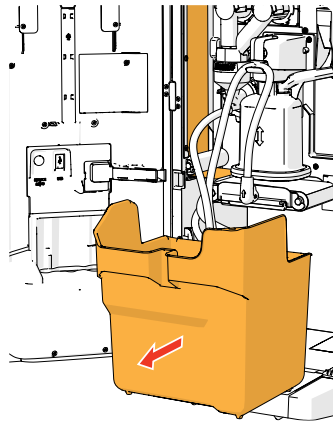
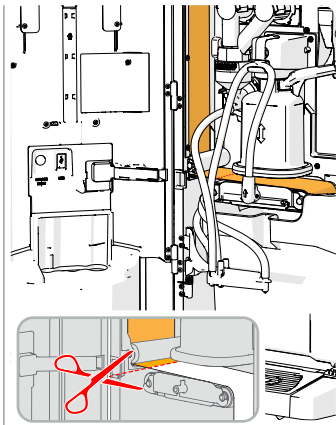

Waste bin

1. open the door
2. cut the filter paper at the indicated location
3. turn the bracket of the beverage outlet towards the door
4. remove the waste bin

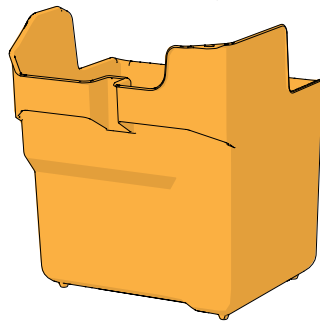

5. empty the waste bin (recyclable)
6. rinse the waste bin with water, use a brush if necessary

3.2 Periodic cleaning (monthly)

Ventilation system

1. switch off the machine
2. open the fan to the back

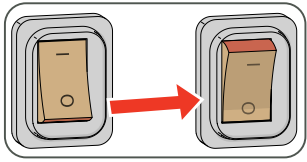

3. carefully pull the rotor of the motor
4. clean the fan housing and grid, using a *damp* cloth

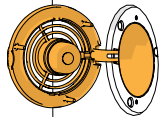
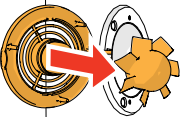

5. clean the fan rotor, using *hot soapy water*
6. dry everything and place the rotor back in place
7. switch the machine back on

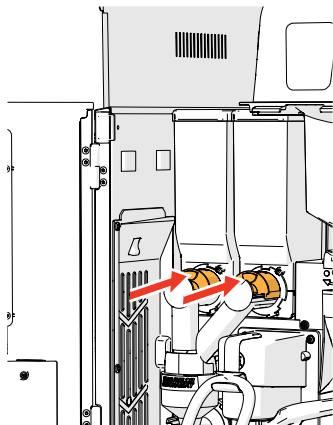
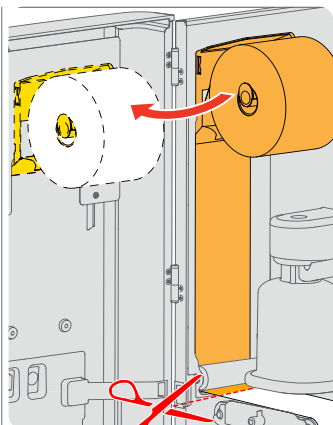
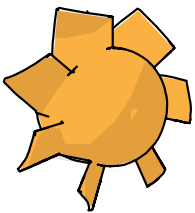

Instant canister(s) and inside

1. open the door and lid
2. cut the filter paper at the indicated location
3. attach the filter paper holder to the door at the position indicated
4. close the "yellow" slider of the canister outlet(s)

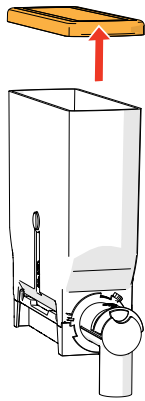
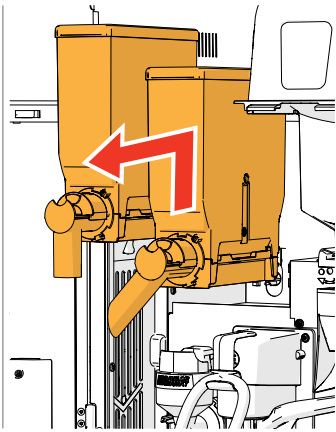

5. take the canister(s) out of the machine
6. remove the lid

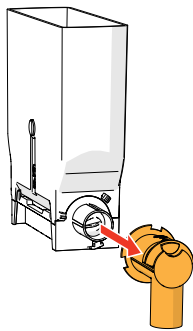
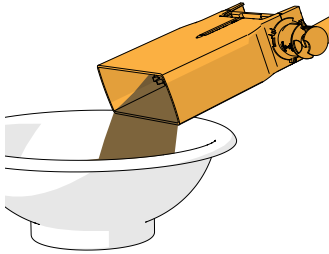

7. pour the ingredients in a dry bowl
8. unlink the outlet from the canister
9. take apart the canister(s)

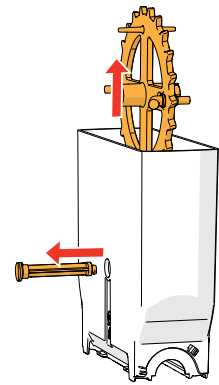
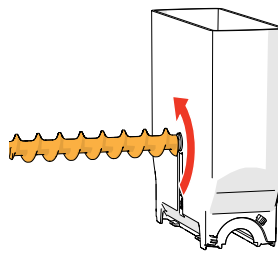
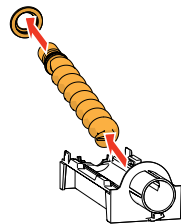
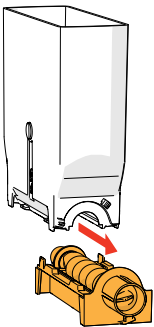

10. clean the canister and outlet with a brush
▶ *Do not use water to prevent the ingredients from clumping and clogging the canister.*

11. clean the *inside* if the machine with a moist cloth

12. refill the canister(s)

13. replace the canister(s) in its/their correct position

14. open the "yellow" slider of the canister(s)

15. replace the filter roll holder

16. feed the filter paper through the brewer

17. close the lid and door

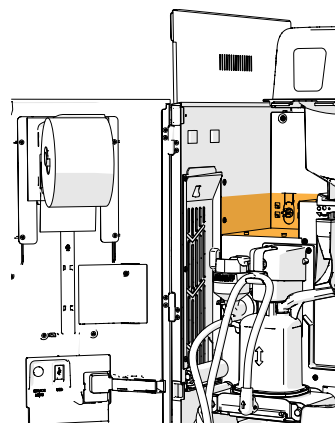
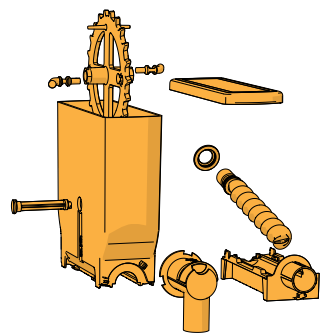

4. Recipes (ex-factory)

4.1 Beverages per configuration

Beverage name	FM100	FM121	FG100	FG121	FG211	FG143	FG233
ristretto	-	X	-	X	X	X	X
espresso	-	X	-	X	X	X	X
caffè crema	-	X	-	X	X	X	X
coffee	X	X	X	X	X	X	X
coffee with milk	-	X	-	X	X	X	X
coffee with sugar	-	X	-	X	X	X	X
coffee with milk and sugar	-	X	-	X	-	X	X
americano	-	X	-	X	X	X	X
cold coffee	X	X	X	X	X	X	X
cappuccino	-	X	-	X	X	X	X
cappuccino dark	-	X	-	X	X	X	X
espresso macchiato	-	X	-	X	X	X	X
latte macchiato	-	X	-	X	X	X	X
caffè latte	-	X	-	X	X	X	X
hot chocolate	-	X	-	X	X	X	X
hot chocolate delux	-	X	-	X	X	X	X
espresso choc	-	X	-	X	X	X	X
wiener melange	-	X	-	X		X	X
hot milk	-	X	-	X	X	X	X
hot water	X	X	X	X	X	X	X
cold water	X	X	X	X	X	X	X
instant 1	-	X	-	X	X	X	X
instant 2	-	-	-	X	-	X	X
instant 3	-	-	-	-	-	X	X
instant 4	-	-	-	-	-	X	-

4.2 Recipes

Beverage name	Volume			Ingredient volume ratio						Ingredient weight (gr./150ml)					dosing sequence
	S	M	L	coffee	topping	sugar	cacao	hot water	cold water	coffee (beans/FB)	coffee (instant)	topping	sugar	cacao	
ristretto	30	40	50	100%	-	-	-	-	-	-	3	-	-	-	co
espresso	40	50	60	100%	-	-	-	-	-	-	3	-	-	-	co
caffè crema	120	160	200	100%	-	-	-	-	-	-	1.875	-	-	-	co
coffee	120	160	200	100%	12.5%	-	-	-	-	9	-	-	-	-	co
coffee with milk	120	160	200	75%	25%	-	-	-	-	9	-	3.5	-	-	co-to
coffee with sugar	120	160	200	75%	-	25%	-	-	-	9	-	-	25	-	co-ca
coffee with milk and sugar	120	160	200	75%	12.5%	12.5%	-	-	-	9	-	3.5	25	-	ca-to-su
americano	120	160	200	33%	-	-	-	66%	-	-	3	-	-	-	co-hw
cold coffee ¹⁺⁴	120	160	200	33%	-	-	-	-	66%	11	-	-	-	-	co-cw
cappuccino ²	120	160	200	33%	66%	-	-	-	-	11	2.875	12.5	-	-	to-co
cappuccino dark ²	120	160	200	33%	66%	-	-	-	-	11	2.875	12.5	-	-	co-to
espresso macchiato ²	75	85	105	75%	25%	-	-	-	-	2.8 ³	2.875	12.5	-	-	co-to
latte macchiato ²	150	200	250	25%	75%	-	-	-	-	11	2.875	12.5	-	-	to-co
caffè latte ²	150	200	250	40%	60%	-	-	-	-	11	2.875	12.5	-	-	co-to
hot chocolate	120	160	200	-	-	-	100%	-	-	-	-	-	-	25	ca
hot chocolate delux	120	160	200	-	33%	-	66%	-	-	-	-	2.5	-	25	ca-to
espresso choc	120	160	200	33%	66%	-	-	-	-	11	-	-	-	25	ca-co
wiener melange ²	120	160	200	33%	33%	-	33%	-	-	9	1.875	16.25	-	8.75	to-ca-co
hot milk	120	160	200	-	33%	-	-	-	-	-	-	16	-	-	hm
hot water	120	160	200	-	-	-	-	100%	-	-	-	-	-	-	hw
cold water ⁴	120	160	200	-	-	-	-	-	100%	-	-	-	-	-	cw

1 33% of the volume is used for brewing coffee, while 66% is used for the cold-water bypass

2 FreshBrew coffee is the standard with these beverages, but when staff customise them, they can choose to use instant coffee instead

3 an espresso macchiato ultimately contains 2.8g / 150ml, which is equivalent to 1.4g / 75ml

4 optional

Brewing your coffee

S I N C E 1 9 4 8

 **BRAVILOR
BONAMAT**